

01679-230288

GURU GOBIND SINGH COLLEGE

Sanghera (Barnala)
Affiliated to Punjabi University, Patiala
Pb. Govt. Aided College, U.G.C 2F, 12B Approved
NAAC 'B' Grade

No:GGSC/9122...

Date: 03/08/2020

Please find the enclosed documents of the clarification of the metric No 4.3.2

Enclosed Documents:

PDF file of Bills Year Wise

Sr No	Year	Page Number
1	2015-16	02 to 17
2	2016-17	18-28
3	2017-18	29-31
4	2018-19	32-33
5	2019-20	34

Principal
Guru Gobind Singh College
Sanghera (Barnala)

03062038281

RETAIL INVOICE

01679-231717, 98151-55717

LUXMI ELECTRONICS

Distributors & Wholesalers of Computer
 Hardware & Peripherals
 A Complete Computer Shop
 Opp. Jama Masjid, Sadar Bazar,
 BARNALA-148101



8938
 Party Name.....

G. G. S. College

Dated... 6-9-16.....

Address.....

Qty	PARTICULARS	Rate	AMOUNT Rs.	P.
2	16 gys Pen Drive n.p.  VAT - 36.....	500	1000	5
		TOTAL	1000	

- 1. Goods once sold will not be taken back
- 2. Warranties/Guarantees are to be given by respective Manufacturer
- 3. We will not be responsible for any warranty claims
- 4. All Disputes are subject to Barnala Jurisdiction

For LUXMI ELECTRONICS

 Signature

3062038281

RETAIL INVOICE

01679-231717, 98151-55717

LUXMI ELECTRONICS



st/30

Distributors & Wholesalers of Computer Hardware & Peripherals

A Complete Computer Shop

Opp. Jama Masjid, Sadar Bazar,

BARNALA-148101

Dated... 14/3/16

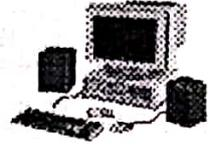

No. 9284

Party Name..... G G Siva Kumar

Address.....

Qty	PARTICULARS	Rate	AMOUNT	
			Rs.	P
6	1687 Pentium HP	500	3000	0
VAT - 36.....		TOTAL	3000	0

1. Goods once sold will not be taken back
 2. All Warranties/Guarantee are to be given by respective Manufacturer
 3. We will not be responsible for any warranty claims
- Disputes are subject to Barnala Jurisdiction

For LUXMI ELECTRONICS

Signature

05072158507

RETAIL INVOICE

Mobile : 94174-93824
98158-62112

Security & Safety Solutions

Auth. Dealers : CCTV, EPABX, Security System, Attendance Machines, Home & Office Automation

KHUDI ROAD, NEAR GOBIND COLONY
BARNALA-148101 (PB.)

Sold to M/s. The Principal
G.G.S. Collage
Sanghera TIN

Invoice No. **150**

Dated : 2/12/15

Your Order No.

Dated :

Our Challan No.

Dated :

S.No.	DESCRIPTION	Qty. in Nos.	Unit Price in Rupees	AMOUNT	
				Rs.	P.
1	Mobile Jamma	SPC	15500	77500	✓
2	wire	1/roll	400	400	✓
TOTAL BEFORE TAX				77900	✓
VAT 6.05%				4712	✓
CST					
S. CHARGE					
NET PAYABLE IN Rs.				82612	✓

Signature

Rs. Eighty two thousand six hundred & Thirteen only 82613

- 1. All Disputes if any arising out of this transaction will be subject to Barnala Jurisdiction.
- 2. All Goods are packed carefully & sent at the risk of the customer.
- 3. Interest @24% will be charged if not paid within 20 days.
- 4. Guarantee/Warranty as per manufacturers/company norms.

For Security & Safety Solutions

E. & O.E. CUSTOMER'S SIGNATURE *Signature*

872158507

RETAIL INVOICE

Mobile : 94174-93824
98158-62112

Security & Safety Solutions

Auth. Dealers : CCTV, EPABX, Security System, Attendance Machines, Home & Office Automation

KHUDI ROAD, NEAR GOBIND COLONY
BARNALA-148101 (PB.)

to M/s. The Principal
G.C.S. college
Banghwa TIN

Invoice No. **357** Dated : 2/12/15
Your Order No. Dated :
Our Challan No. Dated :

DESCRIPTION	Qty. in Nos.	Unit Price in Rupees	AMOUNT	
			Rs.	P.
Mobile Jammer installed labour & test charge			800	
TOTAL BEFORE TAX			800	
VAT				
CST				
S. CHARGE				
NET PAYABLE IN Rs.			800	

forward

Rs Eight Hundred only

- All Disputes if any arising out of this transaction will be subject to Barnala Jurisdiction.
- All Goods are packed carefully & sent at the risk of the customer.
- Interest @24% will be charged if not paid within 20 days.
- Guarantee/Warranty as per manufacturers/company norms.

E. & O.E.

CUSTOMER'S SIGNATURE

For Security & Safety Solutions

[Signature]
Signature

3901084600

RETAIL INVOICE

ORIGINAL COPY

Ph:01651225466

9814975027

ELL BEE TRADING COMPANY

KACHERI BA AAR RAMPURAPHUL
DISTT BHATINDA
RAMPURA

Consignee/Buyer:

SHREE GURU GOBIND SINGH COLLAGE

Inv No.:27

SANCHERA

Date :12-03-2016

TIN:

Terms :CREDIT

Sl No	Description & Specification of Goods	Quantity	Rate	Amount
1	LED SOLAR STREET LIGHT 12WATT	2 Pc	15000.00	30000.00
		2.000		

VAT	SALE AMOUNT	VAT AMOUNT	SURCHARGE	Total :	30000.00
0.00	30000.00	0.00	0.00	Round off:	0.00

FOR DELIVERY

Grand Total ₹ 30000.00

BANK DETAIL : SBOP A/c 55069849956, IFSC=SBOP0000059, HDFC A/c 01872320000852, IFSC=HDFC

Terms & Conditions:

- 1. Goods once sold will not be taken back.
- 2. Interest @ 18% p.a. will be charged if the payment is not made within the stipulated time.
- 3. Subject to "PBI" Jurisdiction only.
- 4. After sales the company will be responsible for warranty

For ELL BEE TRADING COMPANY

Customer Signature

Authorized Signatory

: 07500453452

Original Copy

<< RETAIL INVOICE >>

Parth InfoTech

House No.-27, Khasra No.-420,, Laxmi Vihar, Burari, Delhi-110084
email : hs5453@gmail.com

Party Details :

Guru Gobind Singh Collage
Sanghera

Invoice No. : PI Ret /31
Dated : 02-12-2015

Party TIN :
Party CST No. :

S.N.	Description of Goods	Qty.	Unit	Price	Amount(₹)
1.	FAC T&A + ACCESS SYSTEM- IFACE302 S/N-6316153300398	1.00	Pcs.	25,500.00	25,500.00
2.	BATTERY W/SN Bat20728	1.00	Pcs.	1,500.00	1,500.00

Add : Central Sales Tax @ 12.50 % Total 27,000.00
3,375.00
Add : Installation Charges Total 30,375.00
1,500.00

Grand Total ₹ 31,875.00

Rupees Thirty One Thousand Eight Hundred Seventy Five Only

Terms & Conditions

E.& O.E.

1. Goods once sold will not be taken back.
2. Interest @ 18% p.a. will be charged if the payment is not made with in the stipulated time.
3. Subject to 'Delhi' Jurisdiction only.

Receiver's Signature :

for Parth InfoTech

Authorised Signatory



Sub: Quote for providing and 2, 3 & 4 Mbps (1:1) Internet Leased Line

Dear Sir,

This is with reference to your requirement of Internet Leased Line Connectivity for your esteemed Organization.

This link is provided through *ComeCONNECT*, the ISP division of HFCL Infotel Ltd. (CONNECT) offers world-class Telephony and Internet services, under license from Ministry of Telecommunications, Govt. of India in the state of Punjab and U.T. Chandigarh.

The company has created a state-of-the-art network and technology to ensure seamless and high performance Internet services to all our subscribers. We have installed the latest technology equipment manned by highly trained engineers to give you the best Internet services in the country.

We herewith enclose our techno-commercial details for your perusal. In case of further clarifications or details please feel free to contact the undersigned.

We look forward to your valuable order.
Thanking you,

Yours sincerely,

For HFCL Infotel Ltd.

Mr. Sukhjeet Singh Brar
Key Account Manager
Enterprise & Data Services
Quadrant Televentures Ltd-
9653018731
Sukhjeet.brar@infoelconnect.com

Mr Kamal Sharma
Zonal Head
Enterprise & Data Services
Quadrant Televentures Ltd-
9653018704
kamal.s@infotelconnect.com





COMECONNECT Internet Leased Lines.

Internet Leased Lines will enable the user to take 2, 3 & 4 Mbps (1:1) leased connectivity to the Internet via COMECONNECT. This leased connectivity will primarily be established by using local loop from our telecom services division. This dedicated connectivity enables all users, on a LAN at the customer premises, to access the Internet from their desktop without having to dial up into the Internet. This results in greater ownership, convenience and comfort. The user to transfer high amount of data over Internet and even establish VPN over Internet can also utilize this service.

Components of this service:

The following Diagrams depicts, how this service is implemented:

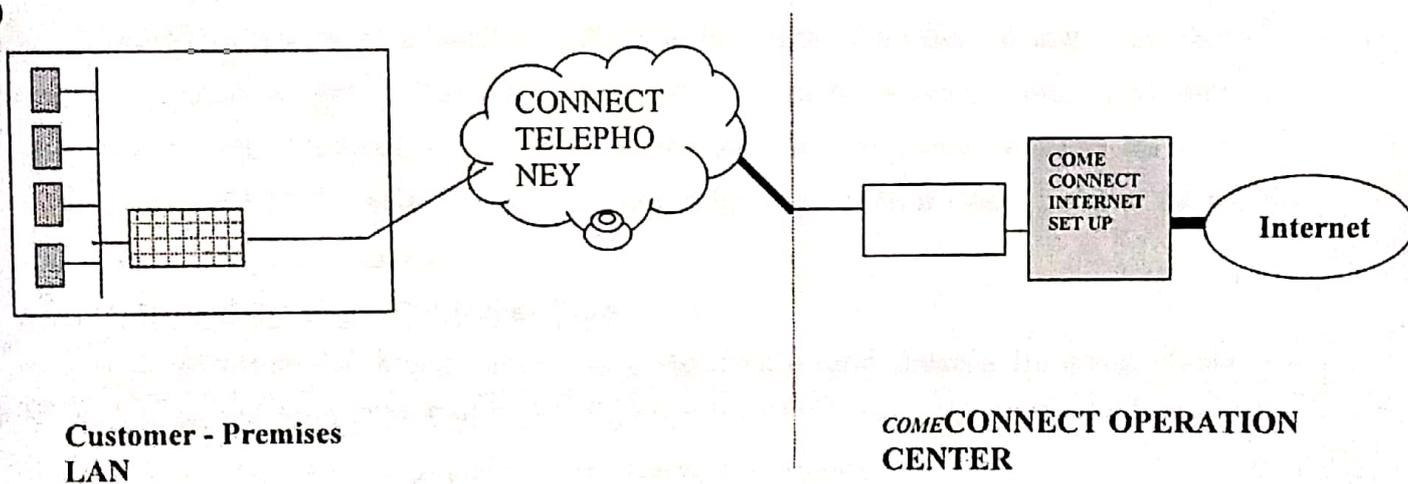

COMECONNECT will provide following services:

- Complete feasibility for establishing connectivity.
- Testing and commissioning of the leased link.
- A dedicated port on a COMECONNECT router.
- Unlimited Internet access via dedicated port.
- A Help Desk that functions as a single point of contact for all COMECONNECT Internet related problems and queries.





COMMERCIAL DETAILS

INTERNET LEASED LINE (ILL) 2, 3 & 4 Mbps (1:1) PURE

No.	Description	Charges (Rs.)
	Charges for Internet Bandwidth 2 Mbps (1:1) Pure (Annual)	1,05,000/- + S.Tax
	Charges for Internet Bandwidth 3 Mbps (1:1) Pure (Annual)	1,30,000/- + S.Tax 1,25,000/- + S.Tax
	Charges for Internet Bandwidth 4 Mbps (1:1) Pure (Annual)	1,50,000/- S.Tax.
	One-Time Installation Charges. on Rf	10,000/- Including Taxes)

25,000
+ S.Tax,

- BW Charges are payable quarterly in advance.
 - Unlimited Data Usage.
 - Static IP's as per requirement will be provided free of cost.
 - MRTG Graphs will be provided free of cost.
 - LOCK -IN- PERIOD ONE YEAR
 - TERMINATION CLAUSE: ONE-MONTH NOTICE AFTER LOCK IN PERIOD
- Note: - All the necessary hardware for commissioning the link will be provided by Quadrant Televentures Ltd. & shall remain the property of Quadrant Televentures Ltd.



भारतीय स्टेट बैंक
State Bank Of India

(06341) BARNALA IFS CODE: SBIN0006341
COLLEGE ROAD
BARNALA
DIST: BARNALA (PUNJAB)-148101

केवल 3 महीने के लिए वैध / VALID FOR 3 MONTHS
27 11 20 11
D D M M Y Y Y

QUADRANT TELEVENTURES LIMITED

क्रेया उनके आदेश पर OR ORDER

RUPEES Twenty Two Thousand and nine hundred only.

अदा करें ₹ 22,900/-

च. No. 10659797885

VALID UPTO Rs. 10.00 Lacs AT NON-HOME BRANCH

Prefix :
1516100003

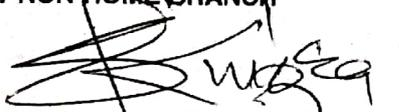
PRINCIPAL, G.G.S. COLLEGE.
Please sign above

MULTI-CITY CHEQUE Payable at Par at All Branches of SBI

⑈ 300232⑈ 148002101⑈ 001297⑈ 31

QUADRANT TELEVENTURES LIMITED
SUBSCRIBER APPLICATION FOR (INTERNET LEASED LINE)



ID: _____
 Name of Person/Company/Firm/Association/Trust GURU G. GOBIND SINGH COLLEGE SANGHERA

Registration No. _____ PAN GIR No. _____
 Contact Name RANBIR SINGH KANGAR Designation PRINCIPAL

SERVICE TERMINATION ADDRESS
 House / SCO / SCF / Plot / Shop / Booth No _____
 Floor No _____
 Building / Estb. Name _____
 Street Name / No/Block No _____
 Locality _____ Landmark _____
 City/Town/ Tehsil _____
 Post Office _____ District _____
 State _____ Pin Code _____
 Tel Nos: _____ Fax _____
 Existing CONNECT Number (if Any) _____
 D.P. No: _____ MSUWLN No: _____

BILLING ADDRESS
 House / SCO / SCF / Plot / Shop / Booth No _____
 Floor No _____
 Building / Estb. Name GURU GOBIND SINGH COLLEGE
 Street Name / No/Block No SANGHERA
 Locality _____ Landmark NR. TAKSHILA SCHOOL
 City/Town/ Tehsil RAIKOT ROAD
 Post Office _____ District BARNALA
 State PUNJAB Pin Code _____
 Tel Nos: 99145-18060 Fax _____
 Existing CONNECT Number (if Any) _____

PERMANENT ADDRESS
 House / SCO / SCF / Plot / Shop / Booth No _____
 Floor No _____
 Building / Estb. Name _____
 Street Name / No/Block No _____
 Locality _____ Landmark _____
 City/Town/ Tehsil _____
 Post Office _____ District _____
 State _____ Pin Code _____
 Tel Nos: _____ Fax _____
 Existing CONNECT Number (if Any) _____

REGISTERED OFFICE ADDRESS (For Private and Public Ltd. Company)
 House / SCO / SCF / Plot / Shop / Booth No _____
 Floor No _____
 Building / Estb. Name _____
 Street Name / No/Block No _____
 Locality _____ Landmark _____
 City/Town/ Tehsil _____
 Post Office _____ District _____
 State _____ Pin Code _____
 Tel Nos: _____ Fax _____
 Existing CONNECT Number (if Any) _____

PROOF OF ADDRESS (FOR BILLING ADDRESS):
 1. Telephone Bill 2. Electricity Bill 3. Arms License 4. Partnership Deed 5. Excise Registration 6. Bank Authorization Letter 7. PAN 8. IT Return
 9. TAN 10. Sales Tax Registration Certificate 11. Others _____

PROOF OF IDENTITY (BOTH FOR INSTALLATION AND BILLING ADDRESS, IF SEPARATE)
 1. Passport 2. Driving license 3. Voter's ID 4. PAN Card 5. Arms License 6. Others (Documents as mentioned overleaf) _____

YOUR SERVICE REQUIREMENTS
 AACS III
 Internet Bandwidth required 3 Mbps (1:1)
 Any other requirement _____

WI-FI POLICY
 QTL reserves the right to disconnect internet services without any prior notice if the customer installs its own Wi-Fi access point and allows unauthorized use of un-secured Wi-Fi network. As per the DoT guidelines the customer is required to ensure security of his/her Wi-Fi network from any kind of misuse of the network by unscrupulous elements. The responsibility to this effect would solely rest with the subscriber.

YOUR PAYMENT DETAIL:
 A) Registration and Installation Charges (payable at the time of sign up) 20,000 In words: 20,000
 B) Rental and usage charges 1,20,000 (C) Billing Cycle: Monthly Quarterly Half Yearly Yearly
 Payment Term: One month charges in advance by 15th of previous month for the next month
 Payment Made by: Cash Cheque Draft Cheque / Draft No: _____ Drawee Bank _____
 Branch _____ Date: _____

PLEASE GIVE YOUR BANK DETAILS:
 Name of Bank _____ Branch _____
 Account No.: _____ Type of Account: Saving Current Others _____

CUSTOMER DECLARATION:
 I/We (herein means an incorporated company/Registered Firm/ Proprietorship/ Government Undertaking/ NGO or any body registered or otherwise comprising of individuals/individual etc., applying for a telecom service) We confirm that the information in this form is true and correct, we have read and understood the terms and conditions provided overleaf and we voluntarily accept them. We further agree that if any changes are made in those terms and conditions from time to time, the same would also be binding on us. We further declare and agree that we are not defaulters of Department of Telecommunications.
 We confirm that whatever is stated above is true and correct and if any information is found to be false then QUADRANT Televentures Ltd (Formerly HFCI, India) Ltd) shall be at liberty to withdraw all the facilities provided to us without any notice or assigning any reason and we shall be liable to pay for the loss which it might have suffered on account of providing the said false information.
 Authorized Signatory _____
 Customer's Signature/ Company Seal / Stamp Guru Gobind Singh College Sanghera (Barnala)
 Name _____ Designation _____
 Day _____/Month _____/Year _____ Place _____

SALES AGENT DECLARATION:
 I confirm that the customer has signed in my presence and I have verified all the original documents required for CONNECT services. I am satisfied that the information furnished in this form is accurate. I confirm having received all the initial charges made in this form.
 Name of Dealer / Sales Executive _____
 Sales Code _____
 Signature _____
 Date: Day _____/Month _____/Year _____
 Dealer's Signature and Stamp: _____
 Zonal Head / Sales Administrator _____

FOR OFFICE USE ONLY
 Customer Account Number _____ Verified / Authorized Not Accepted
 I.P. Addresses allocated _____ Bandwidth provided _____
 Type of Transmission Media: _____
 Date of Activation: Day _____ Month _____ Year _____ Time of Activation _____
 Entered by _____ Authorised Signatory /ISP Incharge _____

GURU GOBIND SINGH COLLEGE

Sanghera (Barnala)

No: G.G.S.C./2865

Date: 27/11/2015

To

Quadrant Televentures Limited,

B-71, Industrial Area, Phase-7,

S.A.S. Nagar, Mohali, Punjab.

SUB: Purchase order of 3 Mbps (1: 1) Internet Leased Line.

R. /Sir,

We are pleased to issue a purchase order of 3 Mbps (1:1) Internet Leased Line our below mention Address:

Annual Recurring Charges of ILL 3 Mbps (1:1) = Rs. 1,20,000/- + S.Tax.

One Time installation Charge : 20,000/- S.+ Tax.

Client Name : GURU GOBIND SINGH COLLEGE
Address : Guru Gobind Singh College Sanghera, Barnala
Contact Person : Dr. Ranbir Singh Kingra
Contact No. : 98153-84075

TERMS & CONDITIONS

1. One month will be given prior to notice for Disconnection
2. Lease line will not be used for call center Purpose.
3. MRTG graph Will be Provided by You
4. Recurring charges should be paid monthly in Advance
5. There Will be Unlimited data Uses
6. ALL the hardware provided will remain the Property of QTL
7. Lock in period one Year from the date of activation.

Principal
 Guru Gobind Singh College
 Sanghera (Barnala)

Punjabi University, Patiala

(Established Under Punjab Act No. 35 of 1961)
(College Section)

Regd.

No. 18307 /College/S-4
Date 15/10/15 /2015

TO WHOM IT MAY CONCERN

This is to certify that **Guru Gobind Singh College, Sanghera (Distt. Barnala)** is affiliated to Punjabi University Patiala since 1972 and recognized under section 2(F) & 12(B) of the UGC ACT, 1956 and the following courses are taught in the college as per approval:

S. No.	Name of the Course(s) and Duration	Affiliation		Period of Validity for the year(s)
		Permanent	Temporary	
1.	Three year BA, BCA	Permanent		Till date
2.	Two year MA (Punjabi, History)	Permanent		Till date
3.	One year Post Graduate Diploma In Computer Application & Post Graduate Diploma In Dress Designing & Tailoring	Permanent		Till date

[Signature]
Dean, College Development Council

[Signature]
Principal,
Guru Gobind Singh College
Sanghera (Barnala)

[Signature]
Principal,
Guru Gobind Singh College
Sanghera (Barnala)

TI 33851016873

RETAIL INVOICE 001679-235429 (S&R)

M/S. GARG TRUNK HOUSE



Near Old Parbhat Cinema,
BARNALA-148101 (Pb.)



Mfg. :- Trunk, Patti, Steel Almari, Cooler, Tub,
Milk Cane & Wheat Doll etc.

1083

Credit

Invoice No.....

Dated... 11/3/2016...

M/s.....

ਗੁਰੂ ਗੋਬਿੰਦ ਸਿੰਘ ਟਰੱਕ ਘਰ, ਮੋਗਾ

VRN/TRN No.....

Dated.....

Sr. No.	Description of Goods	Qty.	Value per Unit Rate	Amount
	ਕੋਲਰ ਦੀ ਮਕਾਨੀ 4 ਮੀਟਰ ਲੰਬੀ	4 PC	6000/-	24000-
				24000 = 0.
				+ 3432 = 0
				27432 = 0
				+ 400 = 0
Total Amount Inclusive VAT				27832 = 00

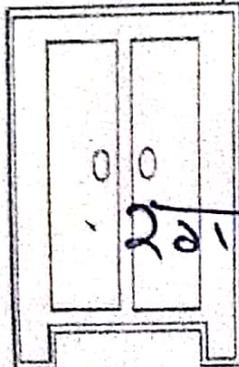

14.3%

VAT 36.....

E. & O.E.

For M/s. Garg Trunk House

Prop.

No. 03062038281

RETAIL INVOICE

01679-231717, 98151-55717

LUXMI ELECTRONICS

Distributors & Wholesalers of Computer
Hardware & Peripherals

A Complete Computer Shop

Opp. Jama Masjid, Sadar Bazar,

BARNALA-148101

Dated 24/4/16

No. **9396**

Party Name G. G. S. College

Address

Qty	PARTICULARS	Rate	AMOUNT	
			Rs.	P.
1	8x8 Ben Sony  Serial		300	
	VAT - 36	TOTAL	300	

For LUXMI ELECTRONICS

Signature

- 1 Goods once sold will not be taken back
- 2 All Warranties/Guarantee are to be given by resteeitive Manufacturer
- 3 We will not be responsible for any warranty claims
- 4 All Debites are subject to Barnala Jurisdiction

3062038281

RETAIL INVOICE

01679-231717, 98151-55717

LUXMI ELECTRONICS

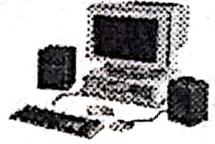
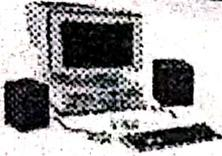

Distributors & Wholesalers of Computer
Hardware & Peripherals
A Complete Computer Shop
Opp. Jama Masjid, Sadar Bazar,
BARNALA-148101

No. **9249**

Dated 7-3-16

Party Name G. G. S. college

Address.....

Qty	PARTICULARS	Rate	AMOUNT	
			Rs.	P.
6	HP Comhuted Bill	26200	157200	0
VAT - 36.....		TOTAL	157200	0

- 1. Goods once sold will not be taken back
- 2. All Warranties/Guarantee are to be given by resteeive Manufacturer
- 3. We will not be responsible for any warranty claims
- 4. All disputes are subject to Barnala Jurisdiction

For LUXMI ELECTRONICS

Signature

2038281

RETAIL INVOICE

01679-231717, 98151-55717

LUXMI ELECTRONICS

Distributors & Wholesalers of Computer
 Hardware & Peripherals
 A Complete Computer Shop
 Opp. Jama Masjid, Sadar Bazar,
 BARNALA-148101

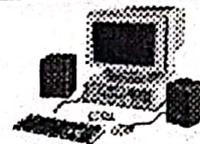
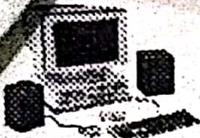

No. **9250**

Dated...7-3-16.....

Party Name.....

G. G. S. college

Address.....

Qty	PARTICULARS	Rate	AMOUNT	
			Rs.	P.
5	Printer Brother Laser	5200.	26000	0
1	Printer Canon	6700.	6700	0
VAT - 36.....		TOTAL	32700	0



1. Goods once sold will not be taken back
2. All Warranties/Guarantee are to be given by resteeptive Manufacturer
3. We will not be responsible for any warranty claims
4. Disbutes are subject to Barnala Jurisdiction

For LUXMI ELECTRONICS

Signature

62038281

RETAIL INVOICE

01679-231717, 98151-55717

LUXMI ELECTRONICS



Distributors & Wholesalers of Computer
 Hardware & Peripherals
 A Complete Computer Shop
 Opp. Jama Masjid, Sadar Bazar,
 BARNALA-148101

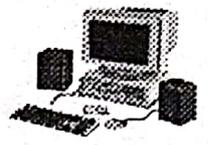

No. **9251**

Dated... 7-3-16

Party Name... G. S. College

Address.....

Qty	PARTICULARS	Rate	AMOUNT	
			Rs.	P.
1	Projector Dell. HP HCL Intel sell DELL	25800	25800	0
VAT - 36.....		TOTAL	25800	0

1. Goods once sold will not be taken back
 2. All Warranties/Guarantee are to be given by resteeive Manufacturer
 3. We will not be responsible for any warranty claims
- isbutes are subject to Barnala Jurisdiction

For LUXMI ELECTRONICS

Signature

2038281

RETAIL INVOICE

01679-231717, 98151-55717

LUXMI ELECTRONICS

Distributors & Wholesalers of Computer
Hardware & Peripherals

A Complete Computer Shop
Opp. Jama Masjid, Sadar Bazar,
BARNALA-148101

Dated... 2-3-16

No. 9252

Party Name G. G. S. College

Address.....

Qty	PARTICULARS	Rate	AMOUNT	
			Rs.	P.
10	Uhs. Gnter  Ball	1500	15000	0
VAT - 36.....		TOTAL	15000	0

- 1. Goods once sold will not be taken back
- 2. All Warranties/Guarantee are to be given by resteeive Manufacturer
- 3. We will not be responsible for any warranty claims
- 4. All Disbutes are subject to Barnala Jurisdiction

For LUXMI ELECTRONICS
Signature

2038281

RETAIL INVOICE

01679-231717, 98151-55717

LUXMI ELECTRONICS

Distributors & Wholesalers of Computer Hardware & Peripherals

A Complete Computer Shop

Opp. Jama Masjid, Sadar Bazar,

BARNALA-148101

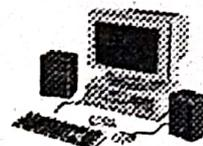

no. 9253

Dated... 2-3-16

Party Name... G. S. College

Address.....

Qty	PARTICULARS	Rate	AMOUNT	
			Rs.	P.
1	15-h LPS month		4000	0
1	LSD Relays		700	0
3	SMPS - power supply	600	1800	0
1	Mother board + Processor		3800	0
3	mouse + key board	800	2400	0
3	(4hs) Battery	700	2100	0
22	Combus Relays	200	4400	0
VAT - 36.....			TOTAL	19200 0

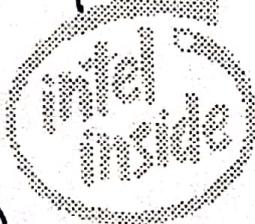

bill

1. Goods once sold will not be taken back
2. All Warranties/Guarantee are to be given by restective Manufacturer
3. will not be responsible for any warranty claims
4. Disbutes are subject to Barnala Jurisdiction

For LUXMI ELECTRONICS

Signature

RETAIL INVOICE

SHIVA AIR CONDITIONERS

Dealer : O GENERAL, BLUE STAR, DAIKIN, VOLTAS, MITSUBISHI HEAVY INDUSTRIES



Handiaya Bazar, BARNALA - 148101 (Pb.)

Invoice No. **8633**

Dated **13/7/2016**

To **GURU GOBIND SINGH COLLEGE, SANGERA**

Qty.	Full description of Goods	Rate	AMOUNT
TWO	1.5 Tn. BLUE STAR SPLIT A.C. S STAR. SNW18SATK ID → 16A00630, 636 OD → 16V08950, 8856	37,000/-	74,000-00
ONE	1.0 Tn. BLUE STAR SPLIT A.C. SNW122CW ID → 15A01371 OD → 15A00255	31,500/-	31,500-00
THREE	STABILIZER COPPER	3300/-	9,900-00
THREE	INSTALLATION CHARGES	1200/-	3,600-00
THREE	VACCINATION "	300/-	900-00
THREE	IRON STAND	500/-	1,500-00

Handwritten signature: Anshu G...

VAT-36..... Total Amount Inclusive of VAT **1,21,400-00**

Note : Service of the product given by company service centre only. The warranty of the product shall be considered void if not installed by us or Repaired by an unauthorized Person /Dealer. Product warranty is given by the company not by dealer. E. & O.E.

For SHIVA AIR CONDITIONERS
 600
 120800/-
 Signature / Authorised Signatory

Cust. Sign

Enhance your Business

SHAKTI TECHNOLOGIES

SCO 3, 2nd Floor, Shakti Complex, The Mall, Bathinda
T-0164 - 5000421, +91-99886-06452 E-mail : rajesh@vbsoftwares.com

SHAKTI TECHNOLOGIES

Party Details

Party Name : Guru Gobind Singh College, Sanghera
Contact person : Sr. Sarabjit Singh / Harkamal Singh
Contact no : 99145-18060

Invoice No. : 484/16

Invoice Date : 01/05/2016

Services	Cost	Qty	Total
1. Cable Bundle Role	5,300	3 roles	15,900
2. Switches (24 Port)	3,600	2 pcs	7,200
3. Switches (16 Port)	2,600	2 pcs	5,200
4. Switches (8 Port)	1,800	1 pcs	1,800
5. RJ 45 Connector	8	150 pcs	1,200
6. Commercial Wifi - Access point	7,500	2 pcs	15,000
7. Jointer/PVC/ Nails/ Pins /Drill Bit	2,450	NA	2,450
8. Network implementation + Installation Cost	---	---	12,000
		Total	60,750
		Advance	- 35,000
		Grand Total	25,750

Rs Twenty Five Thousand Seven Hundred fifty Only.

[Signature]
17/5/2016

<https://mail-attachment.googleusercontent.com/attachment/u/0/?view=att&th=15468b8c3ca165162016>

Pan No: ANNPK3745Q

(Input Tax credit is available to taxable person against this copy)

original copy



<<Val Invoice>>

SHAKTI TECHNOLOGIES

Sco -3 , 2Nd Floor , Shakti Complex , Bathinda
Phone No : 9988606452 Email : rajesh@vbsoftwares.com
Website : www.vbsoftwares.com

Party Details : **Guru Gobind Singh College, Sanghera**
Party Address : Raikot Road , Sanghera
7589205335
PUNJAB
Tin No :

Invoice No : 490
Dated: 21-07-2016

S.N.	Description of Goods	Qty	Price	Amount (R)
1	Visiting And Maintenance Charge	1 User	700.00	700.00 ✓
2	Ethernet Cable	10 Mtr	20.00	200.00 ✓
			11 Mtr	900.00 ✓

BANK DETAILS

Bank Name	Allahabad Bank - Teen Koni (Bathinda Branch)
A/C No.	50159-732340
IFSC	ALLA0211979
MICR Details	151010002

Rupees Nine Hundreds Only

Terms and Conditions

E. OE.

1. No refund can be claimed
2. Interest @ 18% p.a. will be charged for the delayed payment.
3. Upgradation will be required after every calendar year
4. Subject to Bathinda jurisdiction only.

Receiver's Signature :

For SHAKTI TECHNOLOGIES

Authorised Signatory

This is computer generated Invoice and does not required a signature.

Jatinder



I-Tek Logics Pvt. Ltd.
508, Erore Apartment
56, Nehru Palace
New Delhi, 110019
New Delhi

PAN No. AACCE1744Q
Service Tax Registration No. AACCE1744QSD001
VAT Registration No. 07120434481 New Delhi
C.I.N No. : U72900PB2009PTC032836

Bill To :
Guru Gobind Singh College
Raikot Road, Sanghera
Barnala
Barnala, 148101
India

Ship To :
Guru Gobind Singh College
Raikot Road, Sanghera
Barnala
Barnala, 148101
India

Retail Invoice

Invoice No.
Posting Date
Order No.

Page 1
02-11-0616-199
30-06-16
02-01-0616-218

T.I.N. No.	Salesperson	Payment Terms	Shipment Method	Customer Ord'r No.	Due Date	L R. No.	L.R. Date
	Sanjay Jhanji			LETTER HEAD	30-06-16		
No.	Description	Quantity	Unit of Measure	Unit Price	Discount Amount	Amount	
FQC-09478	WinPro 10 SNGL OLP NL Legalization GetGenuine	5	Piece	9,850.00	0.00	49,250.00	
021-10539	OfficeStd 2016 SNGL OLP NL Acdmc	5	Piece	2,650.00	0.00	13,250.00	

10

Total INR	62,500.00
CST Amount @5%	3,126.00
Service Tax Amount @14%	8,750.00
SBCess Amount @0.5%	312.50
KKCess Amount @0.5%	312.50
Total INR Incl. Taxes	75,001.00

In Words SEVENTY FIVE THOUSAND ONE RUPEES AND ZERO PAISA ONLY

Terms and Conditions :

Payment should be made in the favor of " I-Tek Logics Pvt. Ltd."
Interest shall be charged @24% PA for all delayed payments
Cheque retrun charges Rs.500 will be charged on each cheque
All Disputes are subject to Ludhiana Jurductions

Bank Details

Name : ICICI Bank-151505000311
Account No. : 151505000311
RTGS No. : ICIC0001515

For I-Tek Logics Pvt. Ltd.



"Declaration in terms of CBDT Notification (Income Tax) No. 21/2012 dated 13.6.2012:

- We hereby declare that the software items mentioned in the invoice are sold
- o Without any modification.
- o Tax has already been deducted previously u/s 194J of the income tax on these software and made necessary arrangement for remitting the same as per the time line prescribed by Income Tax Act, 1961.
- o Our PAN No is AACCE1744Q

PUNJAB RADIOS

College Road, BARNALA (Pb.)

Dealer : Ahuja P.A. System

ਪੰਜਾਬ ਰੇਡੀਓਜ਼, ਬਾਲਨ ਰੋਡ, ਬਰਨਾਲਾ

No. 1418

Dated 24/6/16

To M/s. G.A.S. College

Sanjay

S. No.	Full Description of Goods	Qty.	Rate	Rs.	P.
	Ahuja Growsnek Mic -	1/1		5025-00	
	Spk - Box Rebr			750-00	
	Amplifier Rebr			100-00	
Total				3875-00	
VAT @ Sur.					
G. Total					



All Subject to Barnala Jurisdiction.

TERMS OF SALE

1. Goods once sold not returnable.
2. Warranty/ Guarantee if any is applicable stands with Company.
3. The Goods sold are to be terms of warranty by the manufacturer or supplier only. There is no obligation on our part.
4. Our firm not responsible for any dispute arising due to defective material or delay in service/ replacement by the manufacturer or suppliers.
5. I have read carefully all above mentioned & overleaf instruction regarding the purchased product.

For Punjab Radios

Auth. Signature

Customer's Signature
E.&O.E.

Form No. VAT 36

RETAIL INVOICE



SHIVA AIR CONDITIONERS

Dealer : O GENERAL, BLUE STAR, DAIKIN, VOLTAS, MITSUBISHI HEAVY INDUSTRIES



Handiaya Bazar, BARNALA - 148101 (Pb.)

Invoice No. **9197**

Dated 11/5/17

To The Principal Guru gobind Singh College Sangra

Qty.	Full description of Goods	Rate	AMOUNT
	One air Condenser Value 5 sets 1-5 To 185 4551685 A17 DA 03523 4511718117 A B 06464 S B o P STBP 0000027 A/c 65183848232 Value set 185	33000/-	33000
			3070
			1200
			500
VAT-36..... Total Amount Inclusive of VAT			37700

Note : Service of the product given by company service centre only.
 The warranty of the product shall be considered void
 if not installed by us or Repaired by an unauthorized Person /Dealer.
 Product warranty is given by the company not by dealer.
 E. & O.E.

For SHIVA AIR CONDITIONERS

[Signature]

Cust. Sign

Signature Authorised Signatory

03802049223

Retail Invoice

MOB. : 93579-07624

98154-91997



DURGA COMPUTERS

Backside Civil Hospital, St. No.1, Near S.D. High School,
BARNALA-148101 (Pb.)

Sale & Service Networking Solutions On Site Service Computer Training

Invoice No. **847**.....

Dated **27/5/17**.....

Iss. **Gurpreet Singh College**
Sanghera

The under mentioned goods as per Order No.....have been delivered/despached to you
vide GR No.....which is enclosed herewith/sent through

S.No.	Particulars	Qty.	Rate	Amount (6.05%)	Amount (8.80%)	Amount (13.75%)
1.	Cabinet	2	10501	21001		
2	Accessories	2	27001	54001		
3.	Hardware	2	8501	17001		
4.	Keys	6	200	1200		
5.	Mouse	6	100	600		
6.	Warranty	25	151	3751		
7.	Plate	4	502	2001		
8.	Warranty	4	100	400		
9.	LED	2	4200	8400		
10.	Shrs	4	1501	6001		
Credit						

TOTAL	209751
On Site Service Charge	
G.TOTAL	209751

General Conditions of Sale :

- All disputes are strictly Subject to BARNALA Jurisdiction only.
- Goods once sold will not be taken back.
- Our responsibility ceases, the moment goods leave our premises.
- Claim if any, must be lodged within 24 hours in writing.
- No payment will be recognised without Firm's printed Receipt.
- Interest @ 24% p.a. will be charged on all over dues.
- No warranty against physically damaged goods or broken seal or burnt products.
- Warranty by Parent Company/Manufacturer of Product as per their conditions
We will just facilitate in getting warranty.

Customer Signature

For **DURGA COMPUTERS**

N : 03802049223

Retail Invoice

MOB. : 93579-07624

98154-91997



DURGA COMPUTERS

Backside Civil Hospital, St. No.1, Near S.D. High School,
BARNALA-148101 (Pb.)

Sale & Service Networking Solutions On Site Service Computer Training

Invoice No. **846**

Dated **26/5/17**

M/s. **Gurpreet Singh Sanghera** **Callage**

The under mentioned goods as per Order No.....have been delivered/despached to you
vide GR No.....which is enclosed herewith/sent through

S.No.	Particulars	Qty.	Rate	Amount (6.05%)	Amount (8.80%)	Amount (13.75%)
1.	Mouse	4	350/-	1400/-		
2.	Installation	13	180/-	2340/-		
3.	UPS battery	1	650/-	650/-		
Credit						

General Conditions of Sale :

- All disputes are strictly Subject to BARNALA Jurisdiction only.
 - Goods once sold will not be taken back.
 - Our responsibility ceases, the moment goods leave our premises.
 - Claim if any, must be lodged within 24 hours in writing.
 - No payment will be recognised without Firm's printed Receipt.
 - Interest @ 24% p.a. will be charged on all over dues.
 - No warranty against physically damaged goods or broken seal or burnt products.
 - Warranty by Parent Company/Manufacturer of Product as per their conditions
- We will just facilitate in getting warranty.

TOTAL	3850/-
On Site Service Charge	
G.TOTAL	3850/-

Customer Signature

For **DURGA COMPUTERS**

33AAAHB9123K1ZM

BILL OF SALE

M: 01679-230387

90413-94432

Prem Chand & Bros.

Pinki Market, Handiaya Bazar

Barnala (Pb.)

Invoice No. **1222**

Dated 10/9/18

Name Principal Guru Ganga Singh Coll

GSTIN Sarotra State Punjab Code 03

Qty.	Particulars	Tax %	Rate	Amount
1	Set PIN	18%	2100/-	2100/-

STATIONERY HUT

Distributor: Flair Pen, Roller Pen, Dora Pencil, Classmate, School Bags, Pencil Boxes, Pencil Kits, Beetal Phone, All Kinds of Stationery & General Supplies

Made in BARNALA Jurisdiction.

Total Amount Before Tax	2100/-
CGST	
SGST	
Total Amount	2100/-

For Prem Chand & Bros.

Signature

TIN : 03AVCPK9919M1Z7

Original Copy

(This copy does not entitle the holder to claim Input Tax Credit)

TAX INVOICE

GOLDEN BATTERY HOUSE BARNALA

COLLEGE ROAD NEAR WATER TANK BARNALA
Tel : 98728 31949 email : rajinderjindal142@gmail.com

Party Details :

PRINCIPAL GURU GOBIND SINGH COLLEAG
SANGHERA

Invoice No. : 813
Dated : 01-10-2018
Place of Supply : Punjab (03)
Reverse Charge : N

Party Mobile No :
Party State : Punjab (03)
GSTIN / UIN :

S.N.	Description of Goods	HSN/SAC Code	Qty.	Unit	List Price	Discount	CGST Rate	CGST Amount	SGST Rate	SGST Amount	Amount(₹)
1.	EXIDE IM-10000 A1H8F716403 A1L8E689323	8507	2.00	Pcs.	13,200.00	0.00 %	14.00 %	2,887.50	14.00 %	2,887.50	26,400.00
	EXIDE S/W P850 UPS HQJ007047	8504	1.00	Pcs.	4,300.00	0.00 %	9.00 %	327.97	9.00 %	327.97	4,300.00
3.	PLATIC TRAY	3924	2.00	Pcs.	50.00	0.00 %	9.00 %	7.63	9.00 %	7.63	100.00

Grand Total ₹ 30,800.00

HSN Code	Tax Rate	Taxable Amt.	CGST	SGST	Total Tax
3924	18%	84.74	7.63	7.63	15.26
8504	18%	3,644.06	327.97	327.97	655.94
8507	28%	20,625.00	2,887.50	2,887.50	5,775.00
Totals		24,353.80	3,223.10	3,223.10	6,446.20

Rupees Thirty Thousand Eight Hundred Only

Terms & Conditions

- E.& O.E.
1. Goods once sold will not be taken back.
 2. Interest @ 18% p.a. will be charged if the payment is not made with in the stipulated time.
 3. Subject to 'Punjab' Jurisdiction only.

Receiver's Signature :

For GOLDEN BATTERY HOUSE BARNALA

Rajinder Jindal
Authorised Signatory

Tax Invoice

JMDELECTRONICS
 PAKKA COLLEGE ROAD
 OPP PUNJAB & Sind Bank
 BARNALA
 GSTIN/UIN: 03CFUPD7250Q1ZV
 State Name : Punjab, Code : 03
 E-Mail : jmdelectronicsbnl@gmail.com
 Buyer
Curu Gobind Singh College Sanghera
 Barnala
 State Name : Punjab, Code : 03

Invoice No. JMD/1920/0293	Dated 2-Sep-2019
Delivery Note	Mode/Terms of Payment By Cheq
Supplier's Ref.	Other Reference(s)
Buyer's Order No.	Dated
Despatch Document No.	Delivery Note Date
Despatched through	Destination
Terms of Delivery	

Sl No	Description of Goods	HSN/SAC	Quantity	Rate	per	Amount
1	SAC-1.5 TON 3 -18XA3T3C-IFB	8415	1 Nos	27,343.75	Nos	27,343.75
2	Stapilzer 165up Digital IFB	9032	1 Nos	2,754.24	Nos	2,754.24
						30,097.99
CGST						4,076.01
SGST						4,076.01
Rounding Off						(-)0.01
Total						₹ 38,250.00

Amount Chargeable (in words) **INR Thirty Eight Thousand Two Hundred Fifty Only** E. & O.E

HSN/SAC	Taxable Value	Central Tax		State Tax		Total Tax Amount
		Rate	Amount	Rate	Amount	
8415	27,343.75	14%	3,828.13	14%	3,828.13	7,656.26
9032	2,754.24	9%	247.88	9%	247.88	495.76
Total	30,097.99		4,076.01		4,076.01	8,152.02

Tax Amount (in words) : **INR Eight Thousand One Hundred Fifty Two and Two paise Only**

Company's Bank Details
 Bank Name : STATE BANK OF INDIA
 A/c No. : 38388967576
 Branch & IFS Code : BARNALA & SBIN006341
 for JMDELECTRONICS
 Prop. Authorized Signatory

Company's PAN : **CFUPD7250Q**
 Declaration
 We declare that this invoice shows the actual price of the goods described and that all particulars are true and correct.

SUBJECT TO BARNALA JURISDICTION
 This is a Computer Generated Invoice